

exact

PipeCut 360 AIR

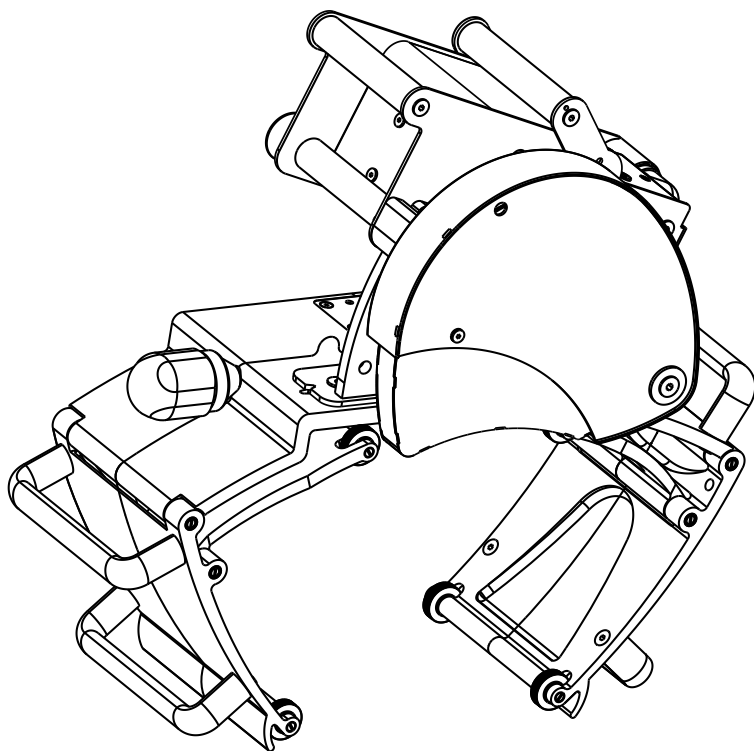

FI	Käyttöohje	X-XX
US	Manual	XX-XX
FI	Espanja	XX-XX
FI	Ranska	XX-XX

exact

PipeCut 360 AIR

Blade information for Exact 360 AIR pipe saws

Exact 360 AIR pipe saws use the following blades:

- Diamond X 180 and X 165 Discs, for cutting cast iron only
- Exact ALU 180 and 165, for cutting aluminum and all kinds of plastics
- Exact Cermet 180 and 165, for cutting steel and stainless steel

PICTURE A

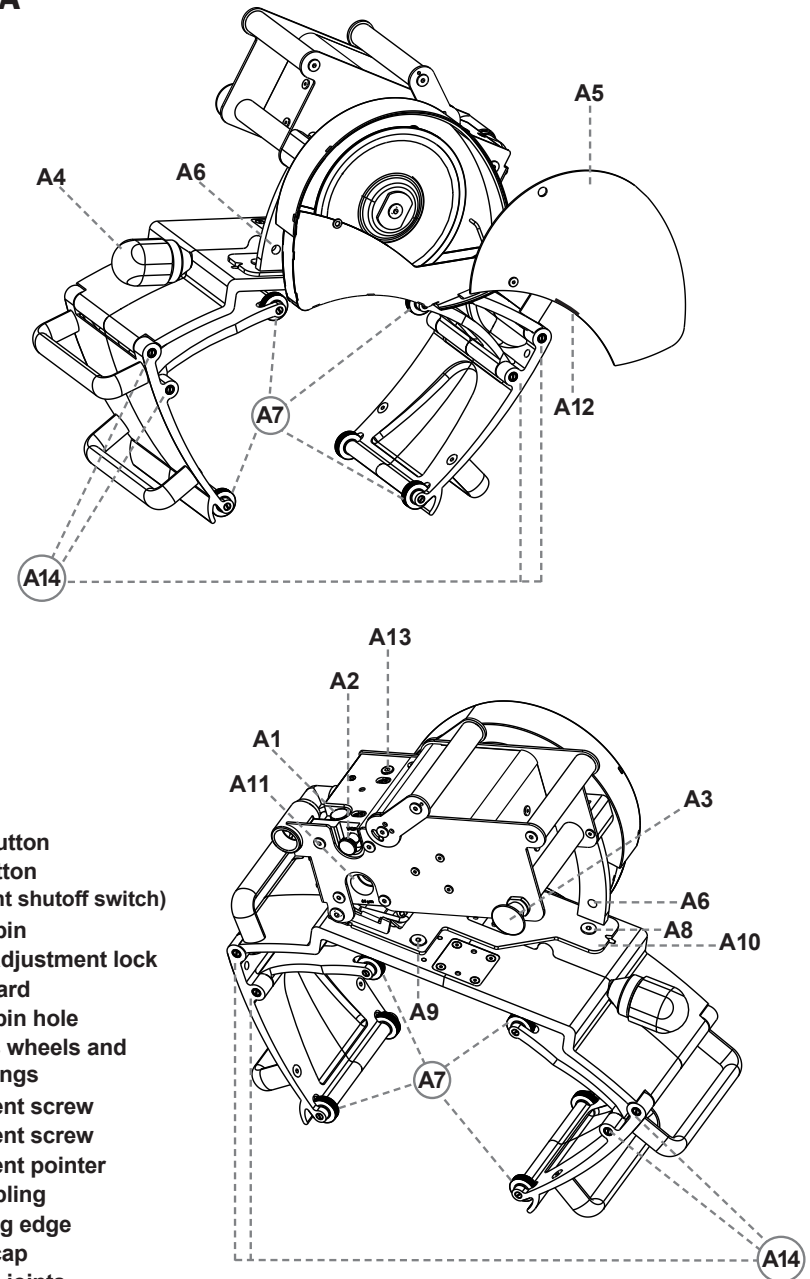

- A1 START button
- A2 STOP button
(air current shutoff switch)
- A3 Locking pin
- A4 Gripper adjustment lock
- A5 Blade guard
- A6 Locking pin hole
- A7 Gripper's wheels and ball bearings
- A8 Adjustment screw
- A9 Adjustment screw
- A10 Adjustment pointer
- A11 Inlet coupling
- A12 Measuring edge
- A13 Oil tank cap
- A14 Gripper's joints

Operating, safety, and servicing instructions

You now have the use of a completely new type of tool. Developed as a safe alternative to dangerous tools used to cut round pipes, the extremely effective Exact 360 AIR has been designed to cut various types of metals and plastics. It is absolutely essential that you carefully read and understand these operating, safety, and servicing instructions before using the pipe saw. Keep this manual conveniently within reach of all pipe saw users. Make sure that all persons using the saw have read and understood the dangers and operating instructions specified in this manual, and always follow the rules and regulations provided by occupational safety agencies. The Exact 360 AIR pipe saw is for professional use only.

Personal safety precautions and requirements

Make sure that the job site where you are working complies with all national, local, and state-specific occupational safety regulations. Only trained persons familiar with all general safety regulations, as well as the possible dangers occurring at job sites, may use this tool. Failure to follow the instructions specified in this manual may cause serious personal injury, damage to the tool, or a hazardous situation.

Installation, storage, maintenance, and disposal

This tool may be installed, stored, maintained, and disposed only by persons who:

- are physically able to handle the size, weight, and power of the device.
- are familiar with all relevant national, state-specific, and local safety regulations, as well as precautionary measures aimed at accident prevention.
- have read and understood these operating instructions.
- have not ingested alcohol, drugs, or medications impairing alertness or the ability to work.

Use

Only professionally capable persons may use this tool.

Users are capable if they:

- are able to handle the size, weight, and power of the device.
- are trained to use this device according to national, state-specific, and local instructions.
- are familiar with, and understand, all national, state-specific, and local safety regulations, as well as precautionary measures aimed at accident prevention.
- have read and understood this manual.
- have not ingested alcohol, drugs, or medications impairing alertness or the ability to work.

Safety information Personal protective equipment

WARNING

Intoxicants:

Drugs, alcohol, and medications may weaken attention, judgement, and/or the ability to concentrate. Impaired reflexes, unsteady balance, hallucinations, and miscalculations may cause serious workplace accidents such as personal injuries, damage to tools and property, or death.

- ⚠ Never use the tool if you are under the influence of alcohol, intoxicating medications, and/or drugs.
- ⚠ If you know about, or notice someone using alcohol, drugs, or intoxicating medications, make sure that he or she is not using the tool.

WARNING

Danger of being caught in moving parts

- ⚠ Do not wear loose jewelry, clothing, or uniforms. Make sure that possible shirtsleeves, shoelaces, and/or pants cuffs cannot be caught by the machine's moving parts or become entangled with any other object or natural feature at the job site.
- ⚠ To minimize the danger of choking, make sure that any collar, tie, or hood cannot become entangled with the device, cords, or accessories.
- ⚠ To minimize the danger of entanglement, make sure that hair and headgear cannot be caught by the device's moving parts, cords, or accessories.

Personal protective equipment must conform to the applicable health and safety requirements. Always use the following personal

protective equipment:

- Hard hat conforming to occupational safety requirements.
- Sufficient hearing protection.
- Safety goggles or visor for eye protection.
- Cut-resistant safety gloves.
- Non-skid safety shoes conforming to occupational safety regulations.
- Breathing mask.

Installation, use, and maintenance: precautionary measures

WARNING

Explosives and flammable materials, liquids, and gases: Danger of explosion

If used in explosive atmospheres, the tool may cause an explosion and/or fire. Explosions are dangerous and may cause extremely serious accidents, injuries, or death. Because the tool often creates sparks while sawing, it must never be used near any kind of potentially explosive or highly flammable material, liquid, or gas. Thoroughly familiarize yourself with the national, state-specific, and local safety instructions related to working near or among, explosive materials.

- ⚠ Never use the tool near explosives or highly flammable materials, liquids, or gases.
- ⚠ Never work in highly flammable or explosive atmospheres.
- ⚠ Make sure that your work area has no hidden gas sources or explosives.
- ⚠ If there are explosives, highly flammable materials, liquids, or gases at your job site, make sure that they do not pose a danger and cannot come into contact with sparks created by the saw.

WARNING
Electric shock

If the device comes into contact with electric circuits or other power sources, it may cause serious injury or death. Always make sure there are no cables, wires, or circuits running inside or near the pipe to be cut that could conduct electricity to the device or user.

- ⚠ Do not work near electrical circuits or other sources of electric currents.
- ⚠ Make sure that your working area has no hidden electrical circuits and that the pipe to be sawn is not in contact with any kind of electrical circuit, power source, cable, wire, or transformer.
- ⚠ Make sure that any water coming from inside the pipe or existing at the job site does not cause the danger of electric shock, and that no water comes into contact with any kind of electrical circuit, power source, cable, wire, or transformer.

WARNING
Compressed air can cause serious injuries.

- ⚠ Always close the air feed, release the pressure from the piping, and detach the tool from the air feed when it is not being used, repaired, or adjusted, for example when blades are being replaced.
- ⚠ Never change blades or service the tool while it is still connected to the compressed air source. Always make sure the device is detached from the compressed air source when performing an inspection or servicing operation. Make sure that the motor

is completely shut off and that the hoses are not pressurized.

WARNING
Danger of vibration

Avoid exposure to vibration; it can damage the nervous system as well as hinder blood circulation in hands and arms. This may in turn cause pain in sensitive joints and possible old injuries.

- ⚠ Always use sharp blades whose condition has been checked. A faulty or damaged blade must never be used for sawing, and should be replaced with an intact blade. Dull, damaged, or faulty blades may intensify vibration.
- ⚠ Avoid exposure to vibration. Long-term exposure to vibration may cause injuries to the user's joints and/or nervous system.

Only professional technicians may test the Exact 360 AIR pipe saw. The pipe saw may not be tested or serviced by persons untrained in the servicing of pneumatic tools. Servicing personnel must be authorized to test these kinds of tools and use a pneumatic system according to national, state-specific, and local regulations.

Safety information

- Overspeed caused by excessive air pressure should be avoided with the pressure regulators. Recommended pressures and air quantities must not be exceeded when using the machine. Excessive pressure or air quantities may cause the breakage of the machine, blade, and accessories, or a hazardous situation resulting in serious personal injury or damage to the equipment.
- Couplings and air hoses must be in good condition. Check the couplings, air hoses, and compressor before use. Never work with a damaged coupling, air hose, or compressor.

WARNING
Only use blades displaying the Exact brand name:

Exact ALU 180
Exact ALU 165
Exact Diamond X 180
Exact Diamond X 165
Exact Cermet X 180
Exact Cermet X 165

- ⚠ Do not use other manufacturers' blades. Exact Tools blades are high quality and have been designed specifically for the Exact 360 AIR pipe saw.

See the manual's *Operating Instructions*, page 17.

WARNING
Failure to comply with these operating instructions may result in serious injuries or death.

- ⚠ Make sure that the pipe being cut is correctly supported, and that each end of the pipe on both sides of the sawing point cannot collapse uncontrollably as the pipe is being cut.
- ⚠ Make sure that sparks do not endanger people or materials. Sparks may cause accidents if they come into contact with flammable materials, liquids, or gases. See the section *Explosives and Flammable Materials, Liquids and Gases*, page 5.
- ⚠ Personal protection equipment must be used as described in the chapter *Personal Protection Equipment*, page 5.
- ⚠ Slipping, stumbling, or falling must be indicated as the reason for a serious accident or fatality. Watch out for excessively long hoses left at the job site.
- ⚠ Work carefully in unfamiliar locations. For example, hidden electrical cables may cause a danger.
- ⚠ Maintain a balanced position and a steady foothold.
- ⚠ If an improperly installed or damaged tool vibrates excessively, react quickly. Shut off the device or cut off the air pressure if possible.
- ⚠ Stay clear of spinning blades; the rotary motion may continue for several seconds after the air feed has been shut off. Do not detach the pipe saw from the pipe before the spinning motion has stopped.
- ⚠ Note that compressed air left in the hose can cause an unintentional startup. Always empty the hose carefully after use. Never detach a pressurized hose.
- ⚠ If there is a fault in the energy feed, press the STOP button (Picture A2).

General safety regulations

To reduce the risk of personal injuries, anyone who uses, installs, repairs, or services this tool, replaces its parts or works in its vicinity, must have read and understood these instructions.

Our objective is to manufacture tools that enhance working safety and efficiency. The most important safety factor for this and any other tool is ITS USER. Your diligence and judgement are the best protection against accidents and injuries. Because all possible risk factors cannot be treated in this manual, only the most important are mentioned. Only professionally trained users may install, adjust, or use this compressed air tool. This tool or its parts may not be altered in any way. Do not use this tool if it has been damaged. If the rating plate displaying the nominal speed or operational pressure, or stickers warning of dangers, are no longer legible or have become detached, they must be replaced immediately.

Consult the following sources for further occupational safety-related information:

- Other guidelines and bulletins provided with the tool.
- Your employer, professional association, and/or labor union
- "Safety Code for Portable Air Tools", (ANSI B186.1), at the time of publication available from the Global Engineering Documents organization at: <http://global.ihs.com/> or telephone number 1 800 854 7179. If procuring the ANSI standards is difficult, contact the ANSI organization at: <http://www.ansi.org/>
- Additional information concerning occupational health and safety is available from the following websites:

<http://www.osha.gov> (USA)
<http://europe.osha.eu.int> (Europe)

Dangers related to the compressed air feed and couplings

- Compressed air can cause serious injuries. Always check the condition of the couplings, compressor, and hoses before use.
- Always turn off the air feed, release the pressure from the pipes and/or hoses, and detach the tool from the air feed source when it is not being used, repairs are being made, or parts are being changed. After the shutoff, the hose is emptied by pushing the START button (Picture A1) to cut off the compressed air flow. The machine will run for a few seconds, after which the hose will be emptied of air. Watch out for the spinning blade and make sure that nothing has been caught in the saw's blade or other parts. Open the coupling only when you are sure that the hose is unpressurized.
- Never point a compressed air hose at yourself or anyone else. Always make sure that the compressed air cannot send objects or materials flying dangerously towards yourself or others.
- Compressed air hoses waving around uncontrollably are extremely dangerous and can cause serious injuries to people, as well as damage to equipment, materials, and the surroundings. Always check that the hoses and couplings are intact and tightly closed. Make sure that couplings are always secured with a durable safety wire. Check the safety wire's condition and durability before use.
- If you use a quick coupling, always make sure that the couplings are intact. Always use a safety wire loop to prevent the hoses' uncontrolled loosening if the coupling breaks. Check the use of the couplings with the applicable safety instructions provided by the manufacturer.

Read the installation instructions carefully.

- If general purpose threaded couplings are used, locking pins must also be installed.
- The air pressure must not exceed 6.3 bar (90 PSI) or the pressure specified on the tool's rating plate. Exceeding the pressure recommendation can result in the machine's breakage or a hazardous situation.
- Check the hose's condition before installation. A broken or worn out hose may cause a hazardous situation.

Danger of catching

- Stay clear of spinning grinding disks or blades. Note that the blade will continue to spin after the closing of the START valve and it may continue spinning for several seconds.
- Entangled clothes, gloves, jewelry, ties, scarfs or long hair in the tool or its accessories can cause choking, scalp injuries, and/or deep wounds.

Never open the blade guard (Picture A5) if you are not sure if the blade or grinding disk has stopped spinning.

Danger caused by flying objects

- The machining of steel and other materials can quickly generate flying debris. Even small objects can injure the eyes and cause blindness.
- Always use impact-resistant protective goggles and a safety mask when operating the tool, working nearby in repair and servicing areas, or changing parts.
- Make sure that other users in the same area are also wearing protective goggles and safety masks.
- Make sure that the pipe to be cut is firmly supported. A weakly or improperly supported pipe may cause a hazardous situation.
- Make sure that the sparks generated by the machine can never, under any circum-

stances, come into contact with flammable and/or potentially explosive materials or liquids.

- Make sure that sparks or shavings pose no danger to other persons at the job site.

Equipment-related risk factors

- Before changing a blade, always shut off the air feed, release the air pressure from the hose and detach the tool from the air feed source.
- Use only the recommended sizes and types of blades.
- Never use a damaged blade. Always check the blade's condition before use.
- Check the blade's attachment before use. For more detailed instructions, see the *Changing Blades* section, page 18.

Operational risks

- Users and servicers must be able to physically handle the tool's size, weight, and power.

Safety information

- Hold the tool properly: be ready to react to any abnormal or sudden movement – keep both hands ready.
- Never use the tool unless the blade is aligned with the material to be cut.
- The Exact 360 AIR is designed to be used with a blade guard that must always be in place to provide protection from shavings and other debris. Never operate a pipe saw if the blade guard is improperly attached.
- Never move the machine while the motor is running or the blade is rotating.
- Do not use the tool if you are tired or your alertness has become impaired for health reasons.
- Do not start working if your foothold or balance is unsteady. Falling while holding a saw can cause a hazardous situation.

Dangers caused by repetitive movements

- When operating the tool, the user may experience discomfort in hands, arms, shoulders, the neck, and other parts of the body.
- Work with a comfortable but secure stance and avoid an awkward or unbalanced working position. Varying your position during longer tasks can minimize discomfort and fatigue.
- Do not ignore symptoms such as continuous or periodic discomfort, pain, anxiety, ache, tingling, numbness, a burning sensation, or stiffness. Stop using the tool, inform your employer, and contact a doctor.

Dangers of noise and vibration

- Loud noises can cause permanent hearing defects and other problems such as tinnitus. Use the hearing protectors recommended by the employer or occupational health and safety regulations.
- Exposure to excess vibration can cause crippling injuries to the nervous system, as well as the blood circulation in hands and arms. Dress warmly and keep your hands warm and dry. If you experience numbness, tingling, pain or paleness of the skin, stop using the tool, inform your employer, and contact a doctor.
- Hold the tool correctly without excess effort; the risks caused by vibration generally increase if you grip the tool too tightly.

Avoidance of unnecessarily high noise and vibration levels:

- Use and service the tool and select, maintain, and change the equipment and accessories according to these operating instructions.
- Use sound attenuation materials to minimize the noise generated by the sawed pipe's resonance.

Job site-related dangers

- Do not use the saw in areas or on terrain where there is the danger of falling or slipping. Make sure that your working position is as steady as possible and that you have a secure foothold.
- Always make sure that the ditch or shaft in which you are working is properly reinforced and that its edges are not in danger of collapsing. Make sure that the terrain is not in danger of giving way or settling.
- If the cutting operation is in a ditch or trench, access to the STOP button may be limited. Always have a co-worker be ready to turn off the air feed to the tool in the event of an emergency. A separate air feed with a shutoff device can also be used for emergency situations.
- Make sure that there are no underground electrical cables, gas sources, flammable materials, or other potentially dangerous objects that could cause a hazardous situation.
- Slipping, stumbling, or falling can result in a serious accident or death. Watch out for hoses at the job site or working platform.
- Avoid the inhalation of dust and vapors, as well as the handling of job site waste that could cause health hazards such as, for example, cancer, birth defects, asthma, and/or dermatitis. Use dust extraction equipment and a breathing mask when the material to be cut releases airborne particles.
- Some sawing generates dust containing chemicals that, according to the state of California, can cause cancer, birth defects, and other reproductive harm.

Examples of these kinds of chemicals include:

- lead from lead-based paints,
- crystalline silica from bricks, cement, and other masonry products,
- arsenic and chromium from chemically-treated rubber.

Your risk from these exposures will vary depending on how often you do this type of work.

To reduce your exposure to these chemicals, work in a well ventilated area and use approved protective equipment such as dust masks specifically designed to filter out microscopic particles. Working without the appropriate protective equipment is prohibited.

- Be extremely careful when working in unfamiliar work surroundings; there may be hidden dangers such as electrical cables, as well as gas, water, or other pipes.
- This tool is not intended for use in potentially explosive atmospheres, nor is it insulated to provide protection from electric shock if it comes into contact with an electrical power source.

DO NOT DESTROY – GIVE TO THE USER**Rating plate and stickers**

The product is furnished with a rating plate and stickers displaying important safety and product information.

**Rating plate with following information:**

Exact PipeCut 360 AIR
 Serial number
 Pressure max. 6.3 BAR (90 PSI)
 Air flow max. 3.9 m³ / min (140 cfm)
 Blade 180 mm or 165 mm (7" or 6.6 inch)
 Max no-load speed 4000 rpm

Exact Tools Oy
 Särkiniementie 5 B 64
 FI-00210 Helsinki
 Finland
 www.exacttools.com

Environment

Separate collection. When your Exact 360 AIR machine is worn out, do not dispose of it with normal household waste; the product must be recycled separately. The separate collection and recycling of used products and packaging facilitates the recovery of materials, reduces environmental pollution, and decreases the demand for raw materials. Local regulations allow the delivery of households' pipe saws to municipal waste dumps or a dealer when buying a new product.

Guarantee

The guarantee's terms became effective on 1 January 2017. If Exact 360 AIR saw becomes unusable due to material or manufacturing faults during the guarantee's period of validity, we will repair the Exact 360 AIR pipe saw or supply a new or factory-reconditioned Exact 360 AIR saw free of charge according to our discretion.

Guarantee period

The Exact Tools guarantee is valid 12 months from the date of purchase.

The guarantee is valid only if:

1. a dated purchase receipt is furnished to the authorized servicing company or it is downloaded on our website in connection with the registration of the guarantee.
2. the Exact 360 AIR saw has not been misused.
3. no attempt has been made by non-approved persons to repair the saw.
4. the Exact 360 AIR saw has been used according to these operating, safety, and servicing instructions.
5. the Exact 360 AIR saw has been delivered to an authorized servicing company during the guarantee's period of validity.

Note:

The Exact 360 AIR saw should be furnished to an authorized repair shop with delivery expenses paid. If the Exact 360 AIR saw is repaired within the scope of the guarantee, the product will be returned with the delivery expenses paid. If the Exact 360 AIR saw is not repaired within the scope of the, guarantee, the delivery expenses will be the customer's responsibility.

Guarantee's limitations:

The guarantee does not the cover following parts, services, or damages:

- Saw blades and diamond blades
- Gripper unit's wheels.
- Blade flange.
- Attachment flange.
- Pulling flange washer.
- Normal wear.
- Misuse or faults and damages resulting from accidents.
- Water, fire, and physical damages.
- Motor breakage or other damage caused by dirt or an unsuitable grade of oil.
- Damages resulting from the use of air whose purity level falls below its reference value.
- Damages resulting from the use of air volumes or air pressures exceeding their reference values.

As a result of continuous product development, the information in this manual may change. Changes are not announced separately.

Operational instructions

Pipe saws are designed with a gripper unit that ensures the saw's secure attachment to the pipe. The saw is attached by turning the gripper adjustment lock (Picture A4) and by tightening it securely to the pipe. Make sure that all of the gripper's wheels turn freely and that there is no sand or debris between the joints. If debris or sand is present, the gripper must be cleaned before beginning the work. If a fault is detected in the gripper unit's mechanism, the saw cannot be used.

PICTURE A

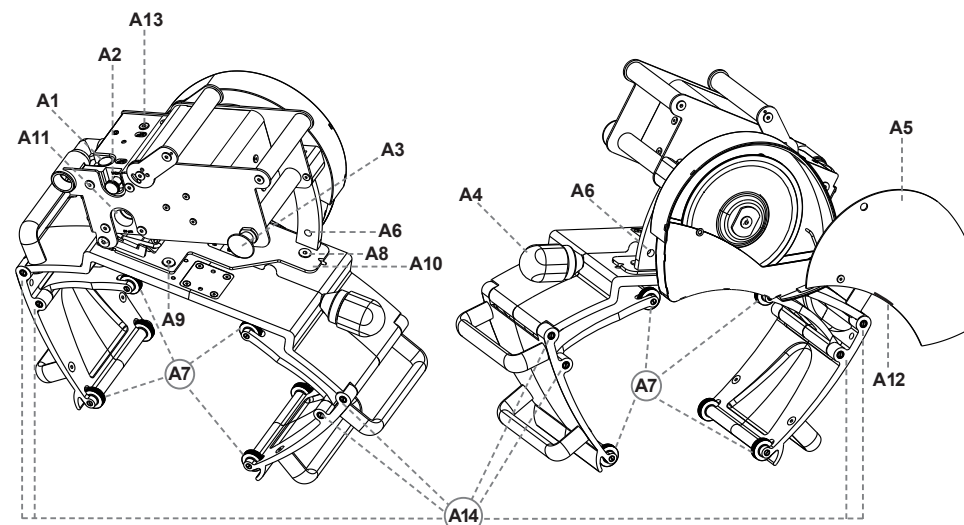

- A1 START button
- A2 STOP button (air current shutoff switch)
- A3 Locking pin
- A4 Gripper adjustment lock

- A5 Blade guard
- A6 Locking pin hole
- A7 Gripper's wheels and ball bearings
- A8 Adjustment screw
- A9 Adjustment screw

- A10 Adjustment pointer
- A11 Inlet coupling
- A12 Measuring edge
- A13 Oil tank cap
- A14 Gripper's joints

Before using the pipe saw, check that:

- the sliding lower blade guard slides freely.
- the motor unit's locking mechanism functions perfectly.
- the gripper unit's wheels turn freely.
- the compressed air's pressure and output comply with the manual's recommendations.
- the pipe to be cut is firmly supported on both sides of the cutting point.
- the compressed air hoses have been attached properly.
- the safety wire preventing the hose's detachment from the machine is securely in place.
- you have the right type of blade, specifically designed to cut the material to be sawed, installed in the machine.
- the blade is in good condition and is tight.

- you have the proper personal protection equipment as specified in the operational safety section of this manual.
- there is enough oil in the oil tank.

NOTE: the motor will not start if there is not enough oil in the oil tank. If the oil starts to run low during the sawing, the motor will shut off and not start before the oil tank has been filled.

Start the motor by pushing the START button (Picture A1). Make sure that STOP button (Picture A2) has been pulled to its out-position. If the STOP button is at its in-position, the motor will not start. Begin sawing as soon as possible after the motor has been turned on to avoid running the motor unloaded or at overspeed.

Determination of pipe's sawing point

Mark the sawing point on the pipe to be cut in a way that deducts one inch from the required measurement. The blade's point of contact with the wall of the pipe is one inch from the measuring edge in the direction of the saw's gripper unit. Always keep in mind that the measuring edge is set one inch more than, or correspondingly less than, the required measurement depending from which direction the required dimension is being calculated.

Attachment of pipe saw to pipe

Place the pipe saw above the pipe to be sawn, ensuring that the gripper encloses the pipe to be sawn. The diameter of the pipe saw's gripper can be adjusted with the gripper adjustment lock (Picture A4). Place the pipe saw at the desired position by using the measuring edge part of the blade guard. (Picture A 12). Adjust the gripper unit according to the pipe's diameter by turning the pipe saw's gripper adjustment lock (Picture A4) and tightening the saw against the pipe. Make sure that the compressed air hose or any other object is not caught between the gripper and the pipe to be cut. Never begin sawing if your fingers, or any other improperly placed clothes or other tools, are between the gripper and the pipe. Also remove any possible sand and/or other debris from under the gripper. Make sure that the saw travels freely. If the saw is not moving properly, detach the saw from the pipe and check the gripper's wheels and ball bearings, (Picture A7) cleaning and oiling them if necessary. If the saw's gripper unit has been damaged, the machine cannot be used until it is repaired.

Piercing and sawing of pipe wall

Make sure that all persons working near the pipe saw have the appropriate personal protection equipment.

Firmly grip the saw's operating handle (Picture D1) with your right hand and hold the gripper adjustment lock (Picture A4) with your left hand.

Pierce the pipe's wall by gently pushing the pipe saw's operating handle directly downwards with an even pressure until the blade has cut through the pipe's wall and the motor unit has locked in the sawing position. You will feel the locking when the locking pin (Picture A3) snaps into the slot designed for it (Picture A6) and moves slightly to the right.

Now that the pipe saw is locked in the sawing position and you can safely begin the pipe's circular sawing. Never feed the saw in the wrong direction.

Filling of oil tank

When the oil tank's piston is visible in the oil level sight glass, and the motor is not running other than by pressing the Start button, oil should be added to the oil tank. The piston must always be pressed downwards when oil is being added.

Make sure that the pressure has been disconnected from the saw and that the intake hose is detached. Unscrew the oil tank's cap. Use a clean tool such as a screwdriver to press the oil tank's piston into the downward position. This pressing is done through the hole in the oil cap. While pressing, make sure that the threading inside the hole remains undamaged. After pressing, the piston will no longer be visible in the oil level sight glass. The best way to fill the oil tank is with a hypodermic syringe. The volume of the tank is approximately 0.05 liters, or about 3 cubic inches. After the filling, screw the oil tank cap back in place. Any possible oil spillage should be carefully wiped away.

NOTE! The level of the oil, for example at the halfway mark, may be visible in the tank's oil level sight glass. This does not, however, indicate the actual level of the oil. The position of the piston, also visible in the oil level sight glass, provides the only true indication of the amount of oil in the tank. When the piston has been pushed down it is no longer visible in the oil level sight glass.

The pipe's circumferential sawing consists of four steps:

1. Begin the sawing by feeding the pipe saw forward while gripping the handles (Picture D1 and D2) until you have sawed approximately one-fourth of the pipe's circumference.
2. Change your grip on the handles: (Picture D4 and D5) now the pipe saw's own weight helps the feeding motion and you can also slightly brake the feeding speed.
3. When the pipe saw is under the pipe, change the position of your grip on the handles (Picture D2 and D3) and pull the pipe saw forward and upwards until you have sawed approximately three-fourths of the pipe's circumference.
4. Once again change the position of your grip on the handles (D1 and D6) and feed the pipe saw until the cutting is completed.

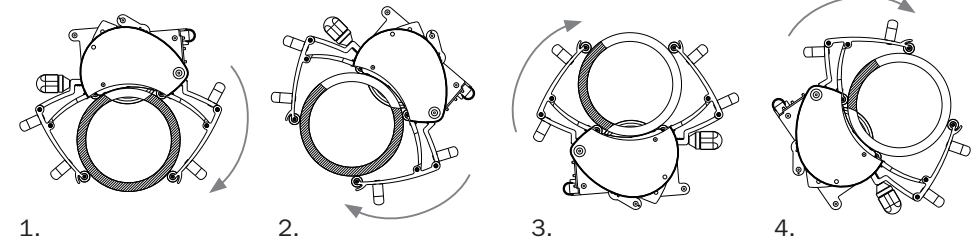
**PICTURE D (Pipe cutting)**

- D1 Handle 1
- D2 Handle 2
- D3 Handle 3
- D4 Handle 4
- D5 Handle 5
- D6 Handle 6

Release the motor unit to the upper position by pulling the locking pin (Picture A3) and press the STOP (Picture A2) button immediately to turn off the motor. Always avoid using the motor without loading.

The feeding speed is selected according to the pipe's material and wall thickness. An excessive feeding speed can damage the blade, overload the pipe saw, and cause a poor sawing result. Control the feeding speed during the entire duration of the cutting. Never completely let go of the saw while cutting.

If problems, unusual noises, or excessive vibrations occurring during the piercing or sawing process require the sawing to be interrupted before the pipe has been cut, turn off the motor by pushing the STOP button (Picture A2) and release the blade by pulling the locking pin out (Picture A3).

When the problem that caused the interruption has been clarified and fixed, resume sawing after checking that the saw or blade has not been damaged. Never start the motor when the motor unit is locked in its sawing position or when the teeth of the blade are in contact with the pipe to be sawn.

Underwater sawing

If the pipe to be cut is partially or completely underwater, or it is possible that water coming from within the pipe will raise the water level at the cutting location so high that the saw will remain submerged during the cutting period, an additional hose should be used in the air exhaust opening. The length of the additional hose should enable it to reach above the water surface during the entire duration of the cutting. Connect the additional hose by threading a $\frac{3}{4}$ inch thread to the opening on the rear section of the pipe saw (Picture A11). Make sure that the hose cannot wave around uncontrollably, which could cause a hazardous situation. If necessary, use a safety wire to support the additional hose, which should always be intact.

An exhaust pipe attached to the machine can detrimentally affect sawing efficiency, particularly if the pipe is long or has a small diameter. When carrying out underwater sawing, the participation of at least two workers is recommended. One worker supervises the progress of the work, and is close to the compressed air shutoff valve in case a possible emergency shutdown of the machine is necessary. The other worker performs the actual sawing.

Use in cold conditions

WARNING: Use warm safety gloves when handling the saw in cold conditions. Cold metal may cause skin injuries.

In cold conditions, note the possible development of brittleness in the material to be cut.

Check the blade screw's tightness before cutting by using the open-end wrench (Picture B3) and hex socket key (Picture B2).

Check before use that there is no moisture or ice inside the compressed air hose you are using. Possible excess moisture and pieces of ice may damage the hose, resulting in personal injuries or damage to the materials.

Make sure that you use oil that suits the operation of compressed air machines in cold conditions. When the temperature falls under -5°C (23°F), make sure that the pour point of the machine's lubrication oil is lower than -25°C / -13°F .

Because moisture remaining in the pipe saw's motor, lubrication system, and other channels may freeze, the pipe saw should be stored and maintained in a warm location. To remove any condensate water that has entered with the compressed air, a dry cutting should be made with the pipe saw indoors and in dry conditions. The stream of warm and dry compressed air fed through the pipe saw's motor, lubrication system, and air vents will remove possible moisture and reduce the risk of freezing.

Do not use solvent-borne de-icing fluids that could damage the lubrication system.

Storage

Store the pipe saw in a dry location shielded from direct sunlight. Do not store the pipe saw on weak structures or a wobbly shelf. Make sure that the storage location can support the weight of the pipe saw. Protect the pipe saw and its parts from possible dents.

Recommendation

Before connecting the Exact 360 AIR to the compressed air hose, always run the compressor until it reaches its operating temperature. When the compressor has reached its operating temperature, blow compressed air out of the hose to remove any possibly accumulated water or debris. Connect the compressed air hose to the machine only after the hose has been cleaned.

Technical data

! While blowing air, be particularly careful when handling the compressed air hose; the end of a hose waving around uncontrollably may injure the user.

- Exact PipeCut 360 AIR
- Minimum Pipe OD 60 mm (2 inch)
- Maximum Pipe OD 355 mm (14 inch)
- Weight 26.8 kg (59 lbs)
- Pressure max. 6.3 bar (90 PSI)
- Free air volume max. 3.9 m³/min (140 cfm)
- Blade 180 mm or 165 mm (7" or 6.5")
- Max no-load speed 4000 rpm
- Air intake and exhaust couplings $\frac{3}{4}$ NPT inside thread
- Air quality requirement, 40 microns/m³ or better
- Operating temperature + 40°C – -20°C / 104°F – -4°F

NOTE! If the recommended pressure and air quantity are not attained, the machine can be used normally, but the machine's efficiency and working speed will decrease correspondingly. The machine is not recommended for use in conditions where the recommended pressure and air volume are less than half of the recommended values.

Cutting depths

Pipe diameter DN mm/inch	Cutting depth mm/inch blade 180 mm/7"	Cutting depth mm/inch blade 165 mm/6.5"
150/6	33.7/1.35	26.2/1.03
200/8	35.8/1.40	28.3/1.11
250/10	39.0/1.55	31.5/1.24
300/12	42.3/1.70	34.8/1.37
350/14	45.0/1.80	37.5/1.47

Recommended motor lubrication oil

MOBIL DTE 24 ISO VG32 Temperature range of this oil is $+5^{\circ}\text{C}$ up to $+40^{\circ}\text{C}$ (41°F up to 104°F) If the temperature is lower than $+5^{\circ}\text{C}$ (41°F) a thinner oil must be used.

The Exact 360 AIR machine cuts all known pipe grades and with the following blades:

- Diamond X 180 and X 165 Discs, for cutting cast iron only.
- Exact ALU 180 and 165, aluminum and all kinds of plastics.
- Exact Cermet 180 and 165, for cutting steel and stainless steel.

Servicing, changing saw blades, and the machine's straightness sawing adjustment

The motor's interior parts should be washed with cleaning fluids, not blown clean with air jets. Do not use strong solvents.

Only professionally capable technicians can test the Exact 360 AIR pipe saw. The pipe saw cannot be tested or serviced by persons who have not been trained in the servicing of pneumatic tools. They must be authorized to test these kinds of tools and use pneumatic systems according to national, state-specific, and local regulations.

Changing blades

PICTURE C

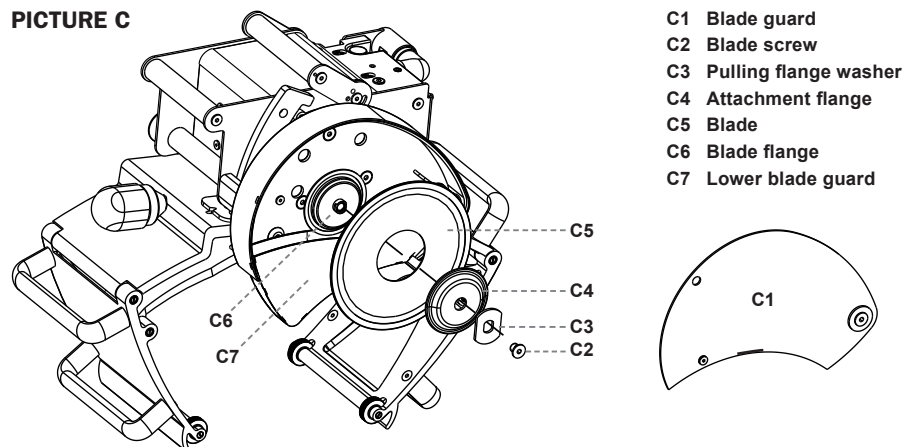

WARNING

⚠ Never change the blade if the machine is connected to a compressed air source or you are not sure if the motor has completely stopped.

Always use undamaged tools when changing blades. Damaged tools will not necessarily achieve the required tightness for the blade's attachment components, which may cause loosening while sawing.

⚠ Do not use other manufacturers' blades.

⚠ Do not use an unchecked blade.

Check the condition of the blade. Cutting with a dull blade causes extra strain on the machine and can lead to a significantly poorer sawing result. A dull or damaged blade must be immediately replaced by a new or sharpened blade. Sawing with a dull or damaged blade can cause extra sparking, detached saw teeth, and thus a hazardous situation to persons and/or materials. Never saw with a bent or damaged blade.

The tools used to change blades are supplied with the machine. A blade can also be changed with other correctly-sized

hex socket keys and open-end wrenches. The Exact 360 AIR pipe saw's blades can be changed in job site conditions.

Open the blade guard (Picture C1) with the hex socket key (Picture B2). After setting the blade guard aside, open the blade screw (Picture C2) with the hex socket key and open-end wrench (Picture B3). Use the open-end wrench as a counterforce to prevent a turning motion by setting the pulling flange washer securely in the place designed for it, after which the blade screw will open by turning the hex socket key. Use force if the screw is tight. Remove the pulling flange washer (Picture C3) and the attachment flange (Picture C4), after which you can set the blade (Picture C5) in place. Make sure that the blade flange located under the blade (Picture C6) is securely in place and that there are no shavings, debris, sand or other functionally detrimental materials between the blade flange and the newly installed blade. Also check that there are no shavings, debris, sand, or other functionally detrimental materials in the attachment flange, screws, or pulling flange washer. If there is unwanted matter

in the blade or other parts, the parts must be cleaned before their installation. When the new blade has been securely placed over the blade flange, set the attachment flange carefully over the blade, then re-attach the pulling flange washer and screw. Tighten the screw with the open-end wrench by using the pulling flange washer as a counterforce.

Blade guard

Always clean the blade guard's inside surfaces (Picture C1), if you have sawed plastic and are now sawing metal pipes. The warming of the metal shavings and blade from the sawing may cause the plastic to melt or smolder, possibly releasing toxic gases. Clean the blade guard regularly and pay particular attention to the functioning of the lower blade guard (Picture C7). The lower blade guard should move freely, and make sure that there is no debris, shavings, or sand in its mechanism's moving parts that could impair its functioning.

Cleaning of gripper unit

Clean the gripper unit regularly with clean compressed air. Lubricate the gripper's trapeze screw, transfer nuts, wheels, hinges (Picture A14), and ball bearings with the applicable oil. Check that there is no debris, chips, or other materials that could hinder its functioning in the gripper.

Straightness sawing adjustment

Open the adjustment screws (Picture A8) and (Picture A9) turn the tool in the adjustment pointer (Picture A10) as shown in the picture: if you want that sawing to go more to the left, turn the entire motor unit to the right.

Filling of oil tank

WARNING:

⚠ Use only the correct type of oil specified for this purpose.

⚠ Keep debris, sand, or shavings from passing into the oil tank. Unwanted materials in the oil tank can damage the lubrication system or the device's other precision mechanics.

Open the oil tank cap (Picture A13) by using the hex socket key (Picture B2). Use appropriate effort to press the piston inside the oil tank down by using a clean stick-like tool such as a screwdriver. You will feel the downward motion of the piston when it clicks in place. Pour oil into the oil tank using a suitable dosing feeder or funnel to avoid spillage. When the oil tank is full, screw the oil tank cap firmly in place. The piston inside the oil tank will snap back to its initial position when the motor is started.

Wintertime use

When the temperature falls under -5°C (23°F), make sure that the pour point of the machine's lubrication oil is lower than -25°C / -13°F

Delivery content

- Exact 360 AIR
- Blade key/straightness sawing adjustment key
- Operating Instructions

Note: Additional hose not included

Picture B
(overview and tools)

- B1 Exact 360 AIR
- B2 Hex socket key
- B3 Open-end wrench
- B4 Operating instructions

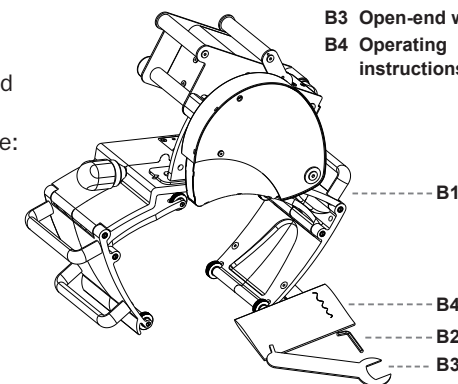

exact
Pipe Cutting System

Exact Tools Oy
Särkiniementie 5 B 64
00210 HELSINKI
FINLAND

Tel + 358 9 4366750
FAX + 358 9 43667550
exact@exacttools.com
www.exacttools.com